

# Data Sheet



Article number: 071131310345035

Description: Cardan drive shaft 0.113.131.001  
S=345 X=35 Bore with keyway

## Measures

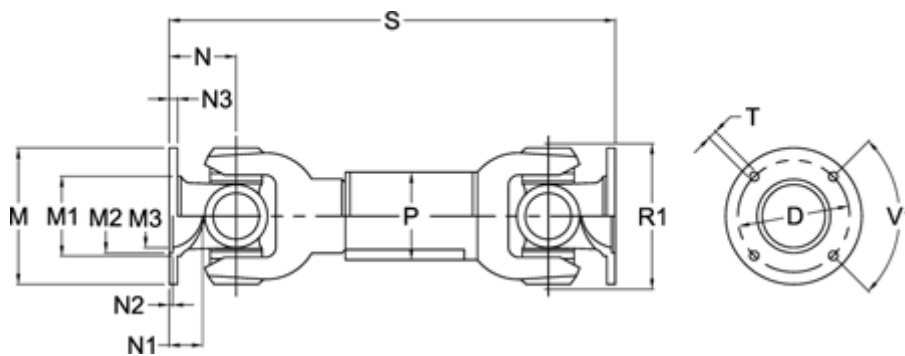

D	= 130 +0,1	N1	= 27.5	T	= 10 B12
Extension X	= 35	N2	= 3 +0,5	V1 degrees	= 45
Flange diameter M	= 150	N3	= 9		
M1	= 104	Number og Flangeholes	= 8		
M2	= 90	P	= 70x4		
M3	= 80	R1	= 125		
Max. Bending Angle degrees	= 18	S min	= 345		
N	= 60	Spline dim. DIN 5480	= 50x2x24		